



Note: This test report is prepared for the customer shown above and for the device described herein. It may not be duplicated or used in part



TABLE OF CONTENTS

1 - General Information	3
1.1 Description of LED Light Sources#	3
1.2 Standards and Reference Documentations	3
1.3 Testing Equipment	4
1.4 Drive Level	4
1.5 Ambient Conditions for Maintenance Test	4
1.6 Photometric Measurement Method and Uncertainty.....	4
1.7 Statement of Traceability	4
1.8 Sample Set.....	5
2 - Summary of Test Result	6
3 - Test Data	7
3.1 Data Set 1, 55°C, 150mA (Lumen Maintenance)	7
3.2 Data Set 1, 55°C, 150mA (Forward Voltage).....	8
3.3 Data Set 1, 55°C, 150mA (Chromaticity Shift)	9
3.4 Data Set 2, 105°C, 150mA (Lumen Maintenance)	10
3.5 Data Set 2, 105°C, 150mA (Forward Voltage).....	11
3.6 Data Set 2, 105°C, 150mA (Chromaticity Shift)	12
4 - DUT Photo	13
4.1 Mechanical Dimensions	13
4.2 DUT Photo.....	13
Directions	14

Bay Area Compliance Laboratories Corp. (Shenzhen)

5/F(B-West) -7/F, the 3rd Phase of Wan Li Industrial
Building D, Shihua Road, Futian Free Trade Zone Shenzhen, Guangdong, China.

Bay Area Compliance Laboratories Corp. (Shenzhen)

5/F(B-West) -7/F, the 3rd Phase of Wan Li Industrial
Building D, Shihua Road, Futian Free Trade Zone Shenzhen, Guangdong, China.
The NVLAP Lab Code is 200707-0



Bay Area Compliance Laboratories Corp. (Shenzhen)

5/F(B-West) -7/F, the 3rd Phase of Wan Li Industrial
Building D, Shihua Road, Futian Free Trade Zone Shenzhen, Guangdong, China.
The NVLAP Lab Code is 200707-0

1.8 Sample Set

Data Set 1: 55°C, 150mA

Part Number: HL-A-5730D1W-S1-08-HR5(LY)
Number of Units: 25
Case Temperature: >53°C
Ambient Temperature: >50°C
Life Test Drive Current: 150mA
Measurement Current: 150mA

Data Set 2: 105°C, 150mA

Part Number: HL-A-5730D1W-S1-08-HR5(LY)
Number of Units: 25
Case Temperature: >103°C
Ambient Temperature: >100°C
Life Test Drive Current: 150mA
Measurement Current: 150mA



2 - Summary of Test Result

Data Set:	Sample Size	Failures Observed:	Test Interval	Test Duration			Reported TM-21 L ₇₀ Lifetime
1	25	0	1000hrs	6000hrs	1.972E-06	1.004	>36000 hours
2	25	0	1000hrs	6000hrs	2.420E-06	1.004	>36000 hours

Average Lumen Maintenance (Percentage of Initial Luminous Flux)

Data Set:	1000hrs	2000hrs	3000hrs	4000hrs	5000hrs	6000hrs
1	100.20%	99.99%	99.79%	99.60%	99.41%	99.21%
2	100.14%	99.88%	99.66%	99.43%	99.18%	98.92%

Average Chromaticity Shift

Data Set:	1000hrs	2000hrs	3000hrs	4000hrs	5000hrs	6000hrs
1	0.0002	0.0003	0.0005	0.0006	0.0007	0.0008
2	0.0002	0.0003	0.0005	0.0006	0.0007	0.0009

Average Lumen Maintenance and Chromaticity Shift VS. Time

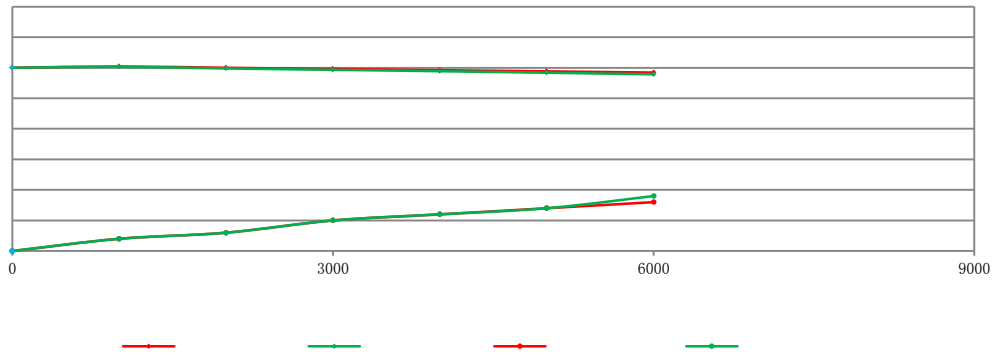

Bay Area Compliance Laboratories Corp. (Shenzhen)

5/F(B-West) -7/F, the 3rd Phase of Wan Li Industrial
Building D, Shihua Road, Futian Free Trade Zone Shenzhen, Guangdong, China.
The NVLAP Lab Code is 200707-0



Bay Area Compliance Laboratories Corp. (Shenzhen)

5/F(B-West) -7/F, the 3rd Phase of Wan Li Industrial
 Building D, Shihua Road, Futian Free Trade Zone Shenzhen, Guangdong, China.
 The NVLAP Lab Code is 200707-0

3.2 Data Set 1, 55°C, 150mA (Forward Voltage)

No.	Forward Voltage (V)						
	0hr(Initial)	1000hrs	2000hrs	3000hrs	4000hrs	5000hrs	6000hrs
1	3.188	3.199	3.204	3.217	3.207	3.211	3.215
2	3.192	3.201	3.207	3.213	3.210	3.214	3.218
3	3.177	3.193	3.195	3.198	3.197	3.207	3.205
4	3.179	3.190	3.196	3.198	3.199	3.198	3.205
5	3.186	3.202	3.198	3.202	3.197	3.203	3.211
6	3.174	3.214	3.192	3.192	3.192	3.195	3.205
7	3.180	3.207	3.198	3.203	3.200	3.202	3.214
8	3.177	3.212	3.194	3.194	3.200	3.197	3.210
9	3.190	3.198	3.208	3.207	3.207	3.216	3.214
10	3.176	3.214	3.195	3.198	3.198	3.196	3.210
11	3.200	3.205	3.217	3.219	3.218	3.219	3.218

12



3.3 Data Set 1, 55°C, 150mA (Chromaticity Shift) 24

No.			CCT(K)						
	0hr(Initial)			1000hrs	2000hrs	3000hrs	4000hrs	5000hrs	6000hrs
1	0.2604	0.5294	2736	0.0001	0.0002	0.0004	0.0005	0.0008	0.0008
2	0.2583	0.5282	2785	0.0001	0.0002	0.0003	0.0004	0.0006	0.0009
3	0.2610	0.5308	2718	0.0001	0.0002	0.0004	0.0005	0.0005	0.0008
4	0.2608	0.5319	2717	0.0002	0.0003	0.0005	0.0006	0.0009	0.0010
5	0.2590	0.5323	2753	0.0001	0.0002	0.0005	0.0006	0.0006	0.0009
6	0.2595	0.5313	2746	0.0001	0.0002	0.0004	0.0005	0.0006	0.0009
7	0.2565	0.5310	2812	0.0001	0.0002	0.0005	0.0006	0.0008	0.0009
8	0.2592	0.5289	2763	0.0001	0.0002	0.0004	0.0005	0.0009	0.0011
9	0.2583	0.5295	2779	0.0001	0.0002	0.0005	0.0006	0.0008	0.0009
10	0.2605	0.5303	2729	0.0001	0.0002	0.0004	0.0005	0.0006	0.0007
11	0.2610	0.5309	2717	0.0001	0.0002	0.0004	0.0005	0.0006	0.0005
12	0.2628	0.5342	2667	0.0002	0.0003	0.0004	0.0005	0.0007	0.0006
13	0.2575	0.5277	2805	0.0002	0.0004	0.0005	0.0006	0.0006	0.0005
14	0.2591	0.5318	2753	0.0002	0.0003	0.0005	0.0007	0.0006	0.0005
15	0.2567	0.5296	2813	0.0002	0.0003	0.0005	0.0006	0.0007	0.0007
16	0.2599	0.5311	2738	0.0002	0.0003	0.0005	0.0006	0.0009	0.0008
17	0.2624	0.5314	2685	0.0003	0.0004	0.0006	0.0007	0.0008	0.0008
18	0.2606	0.5305	2728	0.0003	0.0004	0.0006	0.0007	0.0008	0.0007
19	0.2589	0.5302	2763	0.0002	0.0003	0.0004	0.0005	0.0009	0.0008
20	0.2580	0.5321	2774	0.0001	0.0002	0.0004	0.0005	0.0006	0.0006
21	0.2585	0.5293	2776	0.0002	0.0003	0.0004	0.0006	0.0007	0.0008
22	0.2586	0.5295	2773	0.0002	0.0004	0.0006	0.0007	0.0009	0.0009
23	0.2585	0.5325	2761	0.0002	0.0004	0.0006	0.0007	0.0009	0.0007
24	0.2568	0.5313	2804	0.0001	0.0002	0.0004	0.0005	0.0007	0.0006

Bay Area Compliance Laboratories Corp. (Shenzhen)

5/F(B-West) -7/F, the 3rd Phase of Wan Li Industrial
Building D, Shihua Road, Futian Free Trade Zone Shenzhen, Guangdong, China.
The NVLAP Lab Code is 200707-0

Bay Area Compliance Laboratories Corp. (Shenzhen)

5/F(B-West) -7/F, the 3rd Phase of Wan Li Industrial
Building D, Shihua Road, Futian Free Trade Zone Shenzhen, Guangdong, China.
The NVLAP Lab Code is 200707-0



3.6 Data Set 2, 105°C, 150mA (Chromaticity Shift)

No.			CCT(K)						
	Ohr(Initial)			1000hrs	2000hrs	3000hrs	4000hrs	5000hrs	6000hrs
26	0.2596	0.5304	2747	0.0001	0.0002	0.0004	0.0005	0.0008	0.0008
27	0.2596	0.5306	2747	0.0001	0.0002	0.0004	0.0006	0.0007	0.0009
28	0.2592	0.5322	2749	0.0001	0.0002	0.0003	0.0004	0.0007	0.0007
29	0.2587	0.5305	2766	0.0001	0.0003	0.0004	0.0005	0.0006	0.0008
30	0.2603	0.5330	2722	0.0002	0.0004	0.0005	0.0006	0.0006	0.0008
31	0.2593	0.5303	2755	0.0002	0.0005	0.0006	0.0007	0.0009	0.0011
32	0.2584	0.5286	2781	0.0003	0.0004	0.0005	0.0006	0.0006	0.0009
33	0.2574	0.5295	2798	0.0001	0.0003	0.0005	0.0006	0.0006	0.0009
34	0.2602	0.5318	2730	0.0001	0.0003	0.0005	0.0006	0.0009	0.0008
35	0.2608	0.5329	2713	0.0003	0.0004	0.0005	0.0006	0.0009	0.0008
36	0.2604	0.5305	2732	0.0001	0.0004	0.0006	0.0007	0.0009	0.0009
37	0.2557	0.5307	2830	0.0002	0.0004	0.0006	0.0007	0.0007	0.0008
38	0.2584	0.5302	2773	0.0002	0.0004	0.0007	0.0009	0.0009	0.0010
39	0.2606	0.5294	2731	0.0003	0.0004	0.0006	0.0007	0.0009	0.0011
40	0.2587	0.5316	2762	0.0001	0.0002	0.0004	0.0005	0.0006	0.0009
41	0.2598	0.5346	2727	0.0001	0.0003	0.0004	0.0005	0.0008	0.0010
42	0.2578	0.5272	2802	0.0001	0.0002	0.0004	0.0005	0.0007	0.0008
43	0.2593	0.5318	2748	0.0001	0.0003	0.0004	0.0005	0.0007	0.0009
44	0.2609	0.5304	2721	0.0001	0.0003	0.0004	0.0006	0.0006	0.0009
45	0.2576	0.5283	2801	0.0002	0.0005	0.0006	0.0007	0.0007	0.0011
46	0.2598	0.5313	2740	0.0001	0.0003	0.0005	0.0006	0.0006	0.0009
47	0.2591	0.5317	2753	0.0003	0.0005	0.0006	0.0007	0.0008	0.0010
48	0.2619	0.5315	2697	0.0001	0.0003	0.0005	0.0006	0.0008	0.0011
49	0.2568	0.5297	2810	0.0001	0.0003	0.0005	0.0006	0.0006	0.0009
50	0.2594	0.5321	2744	0.0002	0.0005	0.0008	0.0009	0.0008	0.0010
Avg.	0.2592	0.5308	2755	0.0002	0.0003	0.0005	0.0006	0.0007	0.0009
Med.	0.2593	0.5306	2748	0.0001	0.0003	0.0005	0.0006	0.0007	0.0009
st dev	0.0014	0.0016	33	0.0001	0.0001	0.0001	0.0001	0.0001	0.0001
Min.	0.2557	0.5272	2697	0.0001	0.0002	0.0003	0.0004	0.0006	0.0007
Max.	0.2619	0.5346	2830	0.0003	0.0005	0.0008	0.0009	0.0009	0.0011

4 - DUT Photo

4.1 Mechanical Dimensions

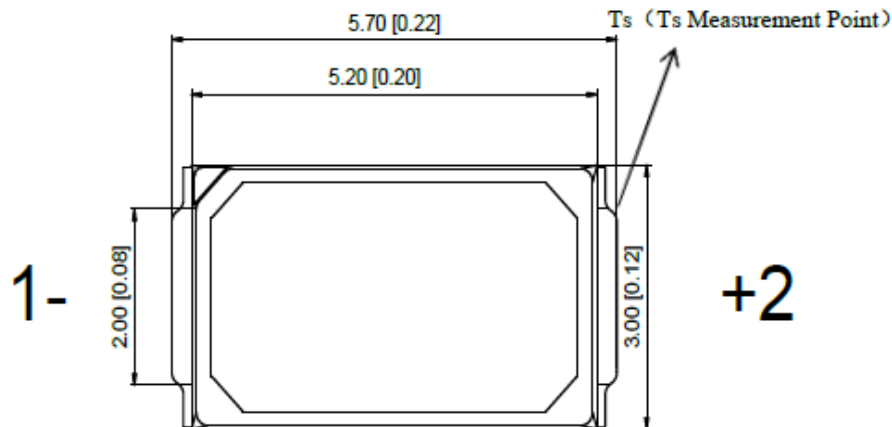

All dimensions are in millimeter

4.2 DUT Photo

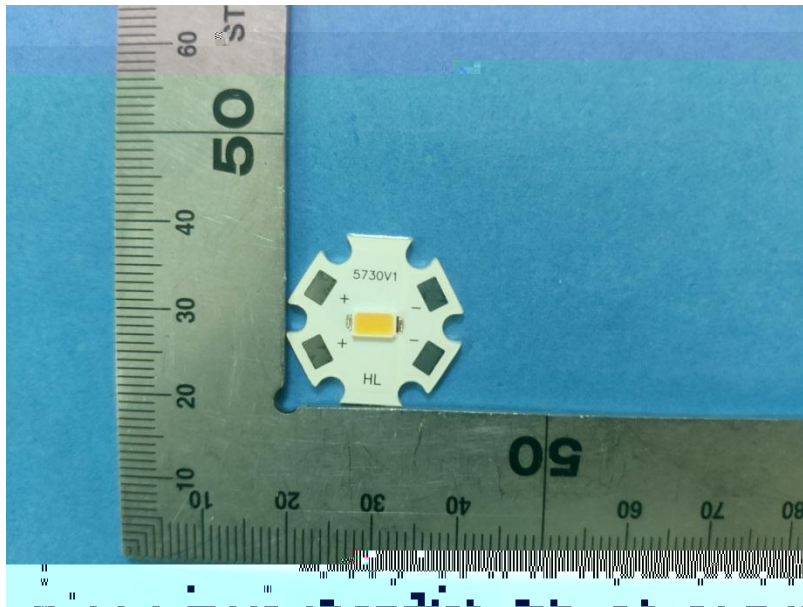



Bay Area Compliance Laboratories Corp. (Shenzhen)

5/F(B-West) -7/F, the 3rd Phase of Wan Li Industrial
Building D, Shihua Road, Futian Free Trade Zone Shenzhen, Guangdong, China.
The NVLAP Lab Code is 200707-0

Directions

*****END OF REPORT*****